

# Optima

Precision Air Conditioner For Critical Application

Cooling Capacity: 17.6kW~134.5kW



OPTIMA product family is designed for medium to large data center. OPTIMA provide precise temperature and humidity control, outstanding reliability and energy efficiency, 24\*7 operation.

OPTIMA product family come with various cooling schemes, including air cooled direct expansion (DXA), water cooled direct expansion (DXW), chilled water single-coil (CW) and double-coil (CWD).

Series segmentation is shown as below:

Unit type	Cooling scheme			Air supply scheme		Cooling capacity kW	Cabinet size code
	DXA	DXW	CW	OVER	UNDER		
OPTIMA.DXA	●			●	●	18.9~103.4	A1-A5
OPTIMA.DXW		●		●	●	17.6~106.7	A1-A5
OPTIMA.CW			●	●	●	24.8~134.5	A1-A5
OPTIMA.CWD			●	●	●	24.8~134.5	A1-A5

### Unit Identification

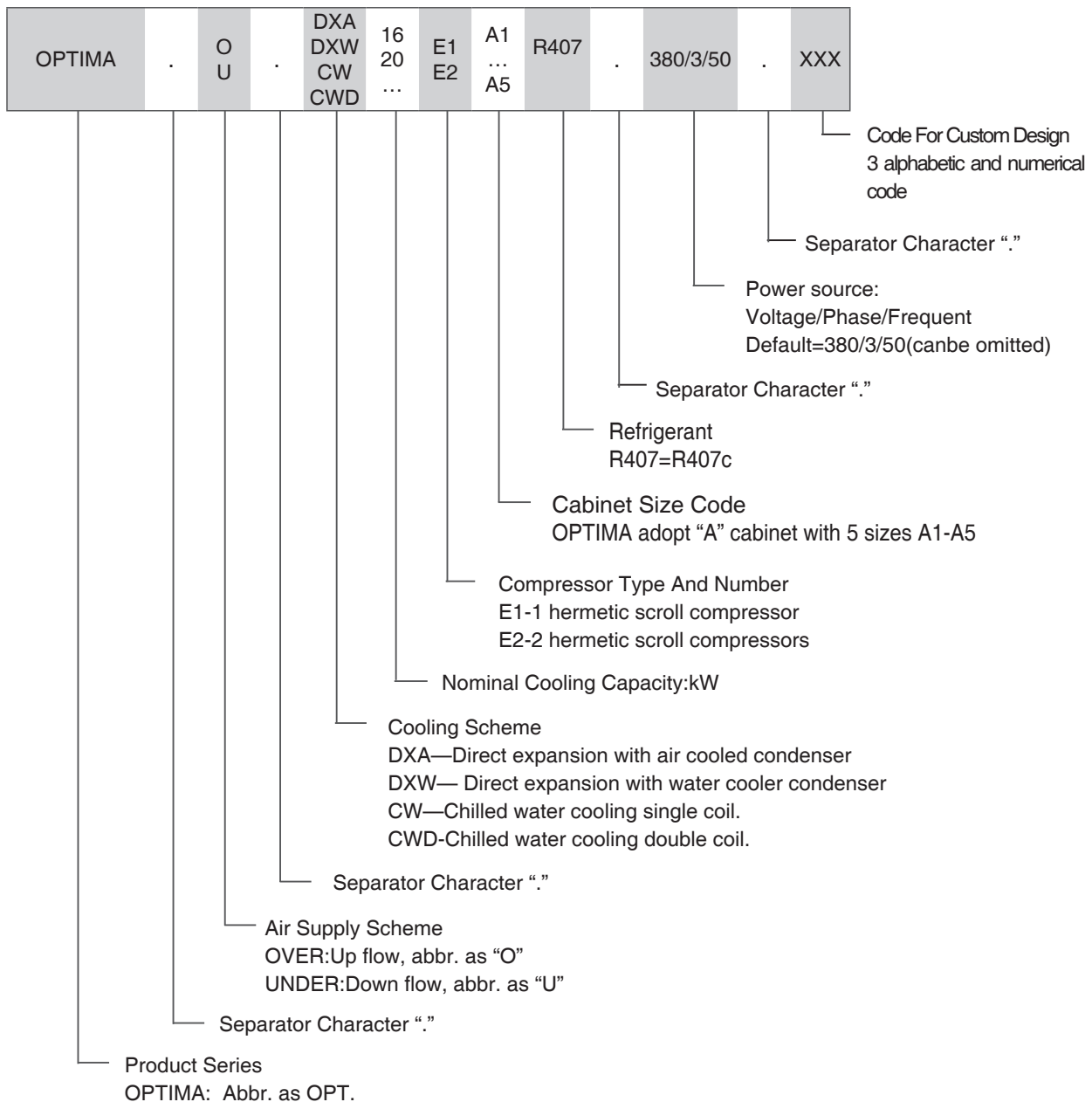

## Operating Range and Control Accuracy

### OPTIMA.DXA

#### Operating Range

Outdoor Temperature:

-40°C ~ +55°C (special options are available for extreme temperature condition)

Piping Length:

Total length of 30 meters of gas and liquid refrigeration piping loop (consult Airsys sales representative for specific installation condition)

Piping Vertical Distance:

Condenser above indoor unit: max. 20m

Condenser below indoor unit: max. 5m

(consult Airsys sales representative for specific installation condition)

#### Control Accuracy

Temperature Range and Accuracy:

Range: 15~35°C, Accuracy:  $\pm 1^\circ\text{C}$ ;

Humidity Range and Accuracy:

Range: 35~80%, Accuracy:  $\pm 5\%$

### OPTIMA.DXW/CW/CWD

#### Operating Range

Water pressure specification:

Higher than the system total pressure drop, lower than 1250kPa

#### Control Accuracy

Temperature Range and Accuracy:

Range: 15~35°C, Accuracy:  $\pm 1^\circ\text{C}$ ;

Humidity Range and Accuracy:

Range: 35~80%, Accuracy:  $\pm 5\%$

## Application

Computer Room and Data Center

Telecom Equipment Room and Shelter

Other Electronic Equipment Room

Healthcare Equipment Room

Laboratory with precision environment

Manufacturing facility requiring precision environment

Storage facility requiring precision environment such as museum, wine cellar

# Working Principles

## OPTIMA..DXA System Schematics

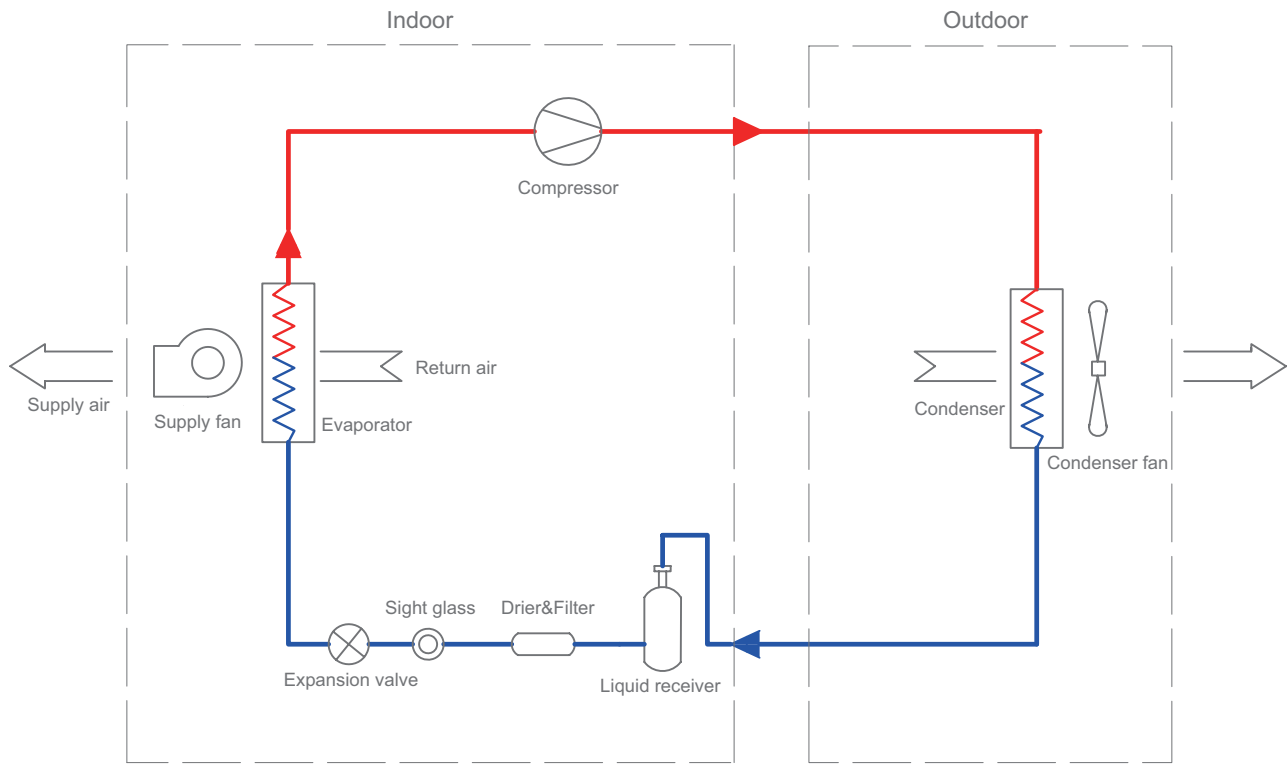

## OPTIMA..DXW System Schematics

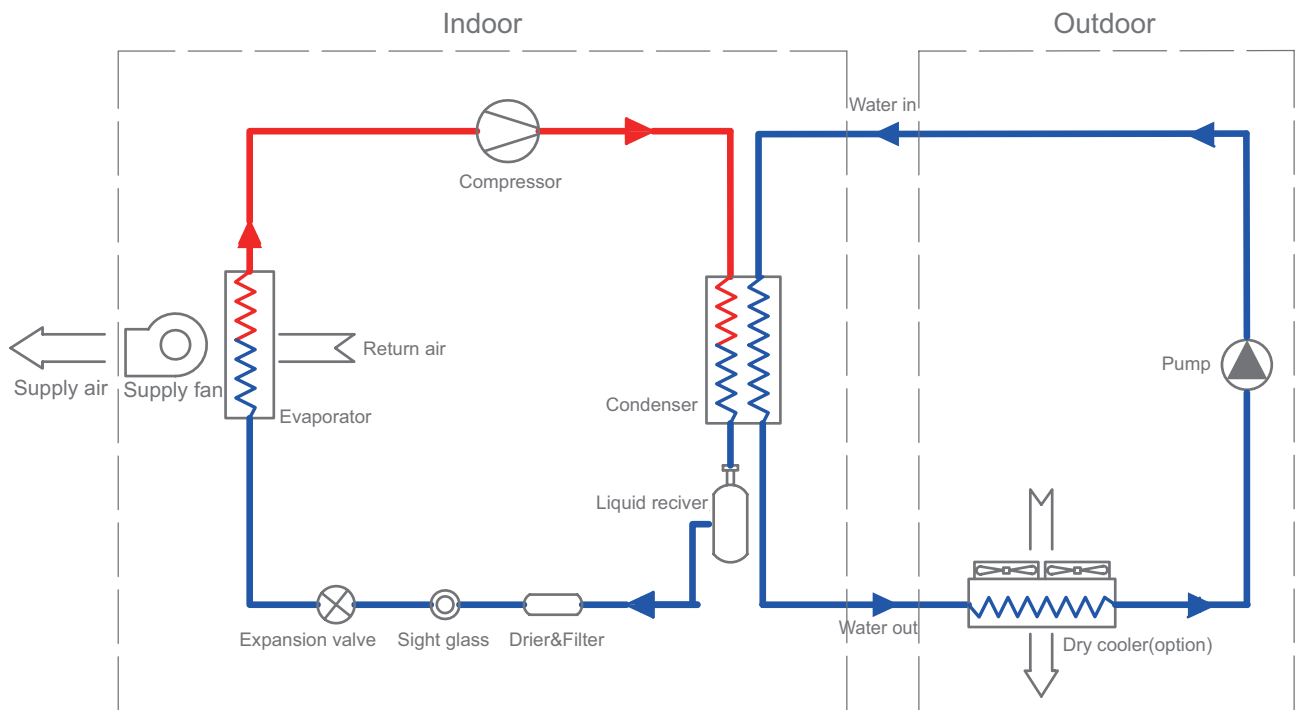

### OPTIMA..CW System Schematics

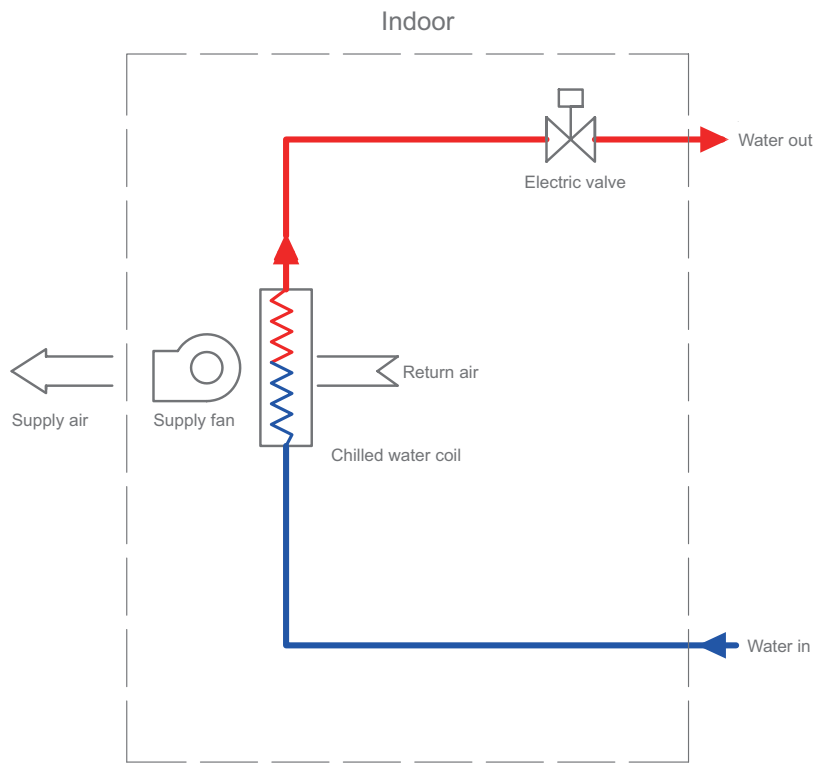

### OPTIMA.CWD System Schematics

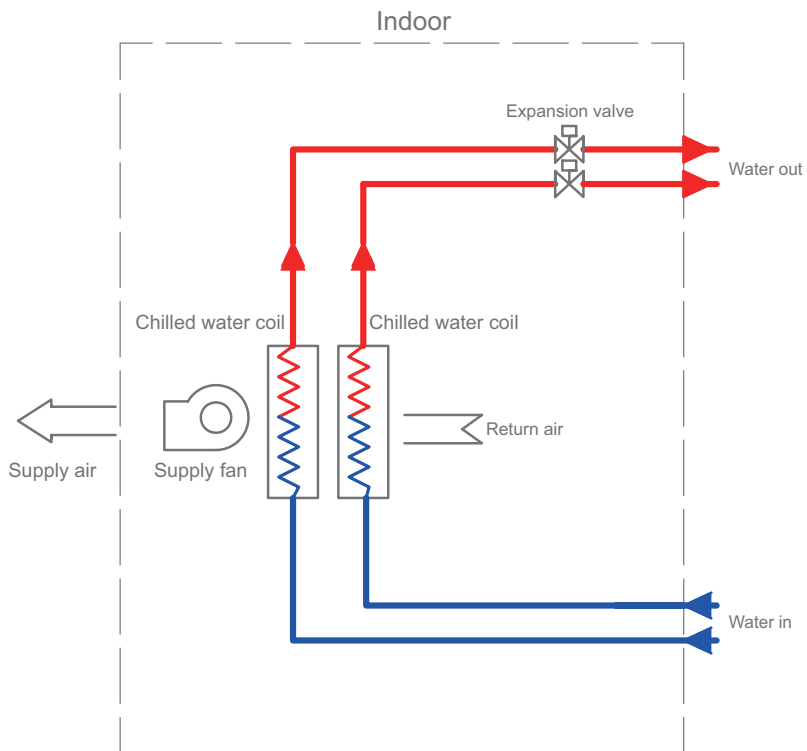

## High Lights

### High Efficiency

OPTIMA product family incorporates various energy saving technologies. The average EER of DXA units is above 3.0.

### Precise Control

The control accuracy for temperature is  $\pm 1^{\circ}\text{C}$  and for Relative humidity is  $\pm 5\%$ .

### Various Cooling Scheme Available

The cooling schemes, include DX air cooled, DX water cooled, chilled water with single coil or double coil, are available.

### Various Air Supply Scheme Available

The supply air schemes, include up flow and down flow; The return air schemes, include up return, bottom return, front return and backward return to meet all different requirements of ICT sites.

### EC Fan

EC motor with external rotor, is highly efficient, reliable and compact. Taking advantage of its' speed variation ability, the unit can achieve:

- 1 Energy-saving by reducing the fan speed when necessary.
- 2 Adjusting external static pressure and air volume according to the external static pressure change.

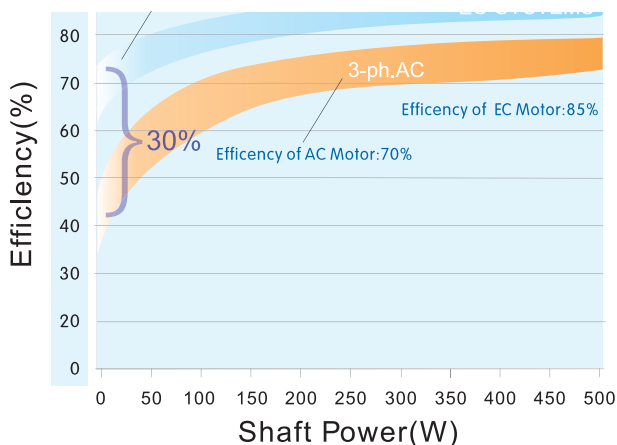

### Scroll Compressor

DXA, DXW units are equipped with scroll compressor, which has characteristics of less vibration, low noise and high efficiency.

### Air Filter

A washable, easy maintainable and durable G4 class air filter is a standard configuration for OPTIMA family. With optional air pressure switch, a clogged filter alarm can be triggered when the filter is dirty.

### Electronic Expansion Valve (Option)

Electronic expansion valve operates more swiftly and precisely than thermal expansion valve, resulting a better control of the system and energy- efficiency.

### Continuous Control System For Condensing Pressure

#### DXA

The unit is installed with pressure sensor which is used for the fan speed control of outdoor unit and maintains the high pressure of refrigeration system within a proper range and keeps the stable operation of the system.

Comparing with On/Off condensing control. The system increases the energy saving significantly and extends the working life of compressor.

The system makes the unit to be able to startup and work at low temperature ambient, up to  $-40^{\circ}\text{C}$  or lower.

#### DXW

The unit is installed with pressure sensor which is used for the water flow valve control of outdoor unit and maintains the high pressure of refrigeration system within a proper range and keeps the stable operation of the system.

### Forced Dehumidification System

The dehumidification is realized by decreasing the evaporator coil surface or by reducing the air flow. These features enable faster dehumidification, increase saving energy and more precise humidity control.

### Optional Energy Saving Running Modes:

There are two kinds of running modes can be chosen:

#### Standard Running Mode:

In this mode the temperature and humidity controlled in narrower range;

### Energy Saving Mode

In this mode, good energy saving can achieve, and the temperature and humidity controlled in a wider range.

The two running modes can be flexibly selected through controller display.

### Electrode Humidifier

Electrode humidifier controlled by microprocessor monitor to adjust the humidifying capacity precisely. The Water quality wash extend the maintenance interval prolong the working life.

### Electric Heater

It is stainless steel pipe twisted with fins around the pipe and it works with a reduced superficial temperature eliminating ionization, thus avoiding peculiar smell.

### Isolated Control Panel

All the electrical and control components are installed on an isolated control panel with orderly wiring and clear labeling, meeting the IEC norm.

### Self-diagnosis:

All the components connected to microprocessor are continuously monitored and controlled and, in case of malfunction, the unit is shut up and the failure is shown on the display.

### Easy Maintenance

Technical compartment recessed from the air flow, housing compressor, humidifier, control and safety devices for ordinary service and preventive maintenance during operation.

## Unit Configuration

### OPTIMA Standard Configuration

Standard Configuration	OPTIMA.DXA	OPTIMA.DXW	OPTIMA.CW	OPTIMA.CWD
Powder painted steel frame	●	●	●	●
Powder painted steel panel with inside thermal and acoustic insulation	●	●	●	●
Backward curve, single inlet, centrifugal fan with 3 phase EC powered electronic commuted motor	●	●	●	●
Copper tube aluminum fin coil	●	●	●	●
Condensing water tray	●	●	●	●
G4 class air filter	●	●	●	●
Temperature and RH sensor at return air inlet	●	●	●	●
Air pressure switch for supply fan protection	●	●	●	●
Microprocessor control	●	●	●	●
Electrical control panel	●	●	●	●
Stainless steel electric heater, various capacity available	●	●	●	●
Proportional controlled electrode type humidifier, various capacity available	●	●	●	●
Hermetic scroll compressor	●	●	—	—
Rubber vibration absorber for compressor	●	●	—	—
Plate heat exchanger as water cooled condenser	—	●	—	—
External equalizer thermostatic expansion valve	●	●	—	—
Sight glass	●	●	—	—
Dry filter	●	●	—	—
Liquid receiver	●	●	—	—
High pressure transducer	●	●	—	—
Pressure switch for high/low pressure protection	●	●	—	—
Continuous control system for condensing pressure	●	●	—	—
Phase sequence protection relay for power supply	●	●	—	—
Motorized 2-way valve	—	—	●	●
Additional copper tube aluminum fin chilled water coil	—	—	—	●

Note: “●” standard configuration, “○” option available, “—” no option available.

## Options for OPTIMA

Option	OPTIMA.DXA	OPTIMA.DXW	OPTIMA.CW	OPTIMA.CWD
Backward curve, single inlet, centrifugal fan with 3 phase AC powered electronic commuted motor	○	○	○	○
Air pressure switch for clogged filter alarm	○	○	○	○
Motorized no-return damper for up flow unit	○	○	○	○
Supply air plenum for up flow unit	○	○	○	○
Supply air plenum for down flow unit	○	○	○	○
Backward air return for up flow unit	○	○	○	○
Installation support stand with adjustable legs	○	○	○	○
Supply air temperature sensor.	○	○	○	○
Floor water leakage alarm kit.	○	○	○	○
Colored touch screen graphical user interface.	○	○	○	○
RS232 communication	○	○	○	○
RS485 communication	○	○	○	○
Pcweb card serve as web based server	○	○	○	○
GSM short message module	○	○	○	○
Electronic expansion valve	○	○	—	—
Low temperature operation kit for outdoor temperature below -20°C (for DXA only)	○	—	—	—
Phase sequence protection relay for power supply	—	—	○	○
Motorized 3-way valve	—	—	○	○

Note: “●” standard configuration, “○” option available, “—” no option available.

## Electric Heater/Humidifier Selection Sheet

Cabinet Size		A1	A2	A3	A4	A5
Heat capacity(kW)	6	●	—	—	—	—
	9	○	●	—	—	—
	12	○	○	—	—	—
	13.5	—	○	●	—	—
	18	—	○	○	●	●
	27	—	—	—	○	○
	36	—	—	—	—	○
Humidification capacity (kg/h)	3	●	—	—	—	—
	5	○	●	—	—	—
	8	○	○	●	●	●
	10	—	—	○	○	○
	13	—	—	○	○	○
	15	—	—	○	○	○

Note: “●” standard configuration, “○” option available, “—” no option available.

## Supply Air Plenum ( Option) Dimensions And Weight

Cabinet Size		A1	A2	A3	A4	A5
Width	mm	875	1480	1750	2490	3095
Depth	mm	470	470	470	470	470
Height	mm	890	890	890	890	890
Weight	kg	32	55	66	87	95



## Functions of microprocessor control system

### Main indications

#### Temperature And Humidity

Return air temperature

Return air relative humidity

#### Working Status

Supply fans

Compressor

Condenser fan

Humidifier water filling and drain valves

Dehumidification activation valve

2 stages electric heater working status

Automatic or manual status

High pressure of refrigeration system

#### Working Hours Of Every Main Component

Supply fans

Each compressor

humidifier

Heaters

#### Alarm Display

Display effective alarms, store and track up to 100 historical alarms (including alarm code, date, time and alarm description)

#### Other control functions

##### Self-diagnosis:

The microprocessor will continuously monitor its own circuit and shut off automatically in case of malfunction.

##### Pressure Protections For Compressors

Double protection on high pressure by both high pressure transducer and pressure switch.

Protection on low pressure by pressure switch.

##### Motor Overload Alarm For Compressor, Supply fan, Electric heater and Condenser fan

prevent damages of component motor from voltage unbalance, low voltage and phase loss.

##### On-off Control Of Compressor

By setting the start-up relay time, minimum working time, minimum on-off interval and number of start-ups per hour to assure the reliability and to prolong the life of the compressor.

##### Sensor Failure Alarm:

The microprocessor will shut down the unit and send out alarm signal in case of any failure of temperature sensor and pressure transducer.

##### Power Supply Failure Alarm:

The microprocessor will shut down the unit and send out alarm signal in case of any failure of the power supply such as phase loss, phase sequence mistake, and voltage out of range.

##### Unit Random Insertion:

The units can start-up automatically after the power recovery. The microprocessor has 2-60 seconds of random insertion to avoid current shock caused by multiple unit start-up at the same time.

##### Floor Water Leakage Alarm

When detecting the water on the floor with the water leakage alarm kit, the microprocessor will send out an alarm.

##### Humidification System Alarm

Microprocessor provides various alarms to the humidification system, such as high/low current, high/low water level, cylinder life, high/low conductivity, to assure the reliability and to prolong the life of the humidifier.

##### Condenser Pressure Control

Microprocessor monitor the compressor discharge pressure and control the steadily control the pressure by changing the speed of the condenser fan. This feature enable more stable operation, low noise, energy saving and low ambient temperature start-up and operation.

##### Manual Control

It is able to manually switch on/off all the major components during the commissioning and service of the unit.

##### Operating Scheduling:

This function allows the user to set daily or weekly operating schedule.

##### Multi-unit Group Control

When multiple units are installed in one room, the operating strategy such as rotation, standby, can be achieved by group networking.

##### Acoustic And Optical Alarm Signaling:

The room temperature, humidity and working status of all the components are displayed on the controller. When a failure occurs, acoustic buzzer is energized and the failure message is displayed on the controller display.

##### 4 Levels Of Password:

Unit has 4 password dedicated to different operation and maintenance jobs, this will prevent the unit from wrong or unauthorized operation.

## Modifiable Parameters

### Basic Running Parameter

Basic Running Parameters can be modified by customers according to the customer need, for example: temperature and humidification setting

### General Parameters

The default parameters can be modified by service engineer during routine maintenance, for example: temperature and humidity range, precision

range adjustment, temperature and humidity dead zone setting, highest and lowest temperature and humidity setting, high pressure alarm setting, start and stop schedule setting, etc.

### Advanced Parameter

For example: alarm delay adjustment, backup rotation setting, condensing fan working point setting, the compressor minimum start interval setting  
The unit can be initialized if necessary

Note: more details, please refer to the User Manual

## Remote Control And Monitoring Network

The unit can be remote controlled or monitored by many kinds of methods as follows:

- 3 kinds of local direct cable connection
- 3 kinds of LAN network connection
- 4 kinds of wireless network connection

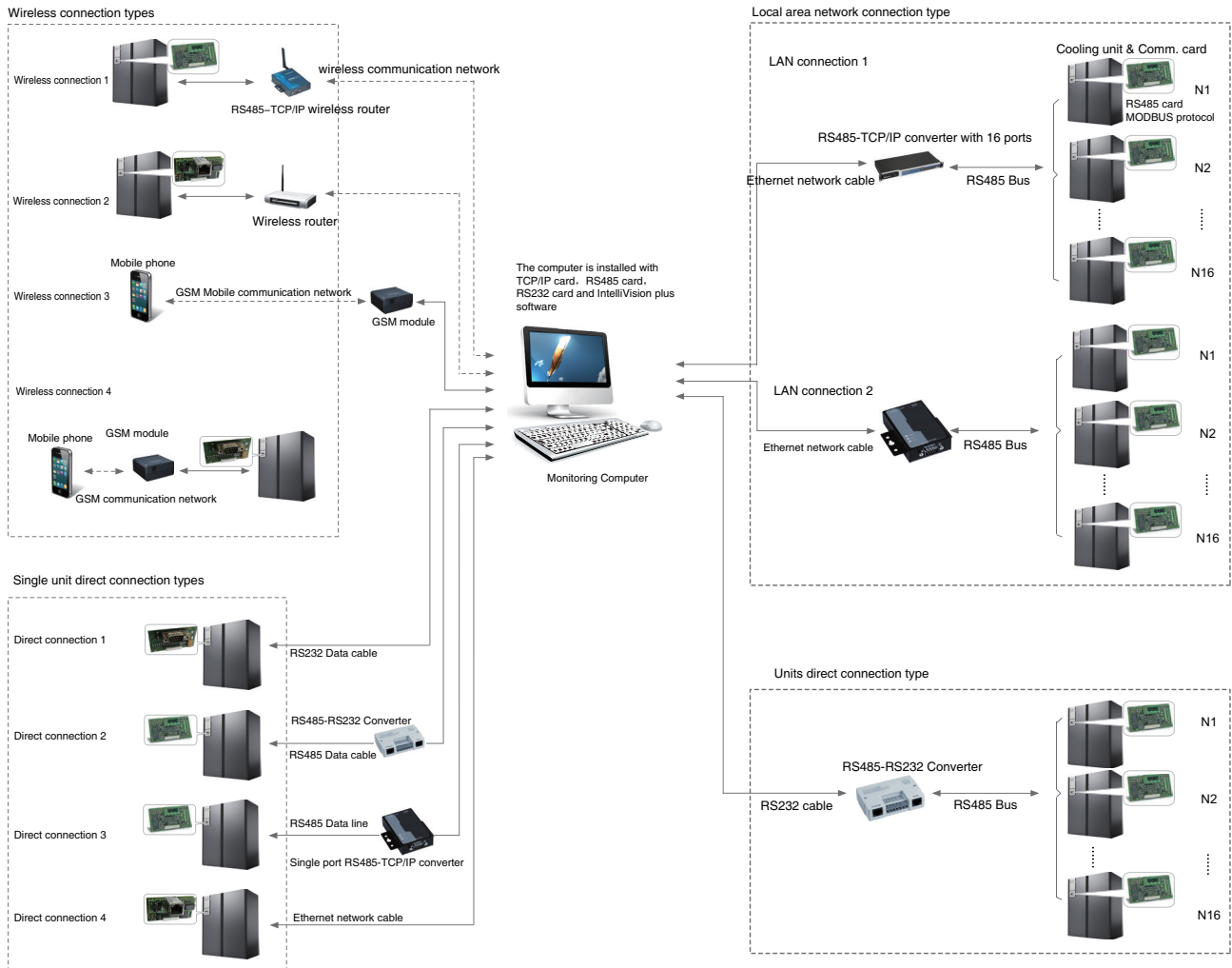

# Technical Parameters

## OPTIMA.DXA

Unit Model		16E1A1	20E1A1	26E1A2	30E1A2	35E1A2	40E1A3	50E2A3	60E2A4	70E2A4	80E2A4	90E2A5	100E2A5
Supply air scheme		O/U											
Cooling capacity													
Total (2)	kW	18.9	22.0	28.5	31.9	37.6	46.6	55.1	65.3	74.5	84.6	90.7	103.4
Sensible(2)	kW	18.3	20.7	26.2	29.3	35.3	44.3	51.1	59.9	71.4	79.4	86.1	97.7
Total (3)	kW	19.5	22.7	29.4	32.9	38.8	48.0	56.8	67.3	76.8	87.2	93.5	106.6
Sensible(3)	kW	18.5	20.9	26.5	29.7	35.7	44.8	51.6	60.5	72.2	80.3	87.0	98.8
Compressor													
Type		Hermetic scroll											
Power input(2)	kW	3.9	4.4	5.8	6.5	7.7	8.7	2×5.8	2×6.5	2×7.7	2×8.7	2×9.7	2×11.6
Current(2)	A	7.5	7.9	11.3	12.5	14.3	16.3	2×11.6	2×12.7	2×14.5	2×16.3	2×17.8	2×21.6
Power input(3)	kW	4.1	4.6	6.1	6.8	8.0	9.0	2×6.1	2×6.8	2×8.0	2×9.0	2×10	2×12
Current(3)	A	7.7	8.1	11.6	12.7	14.8	16.7	2×11.9	2×12.9	2×14.8	2×16.7	2×18.2	2×22.3
Supply fan													
Type		Caseless backward centrifugal fan											
Qty. of fan		1	1	1	1	1	2	2	3	3	3	3	3
Air volume	m³/h	5750	6320	8900	9600	9600	12600	13600	17800	19200	21000	24600	27900
External static pressure (ESP) (4)	Pa	Standard ESP is 75Pa, adjustment range is 50~300Pa											
Power input	kW	1.0	1.2	1.4	1.7	1.7	2.4	2.8	3.6	3.9	4.0	4.2	5.1
Current	A	1.7	1.9	2.1	2.6	2.6	3.8	4.2	5.7	6	6.3	6.3	7.8
Air filter		G4 plate											
Electric heater(5)													
Type		Stainless steel electric heater											
Heating capacity	kW	6	6	9	9	9	13.5	13.5	18	18	18	18	18
Working steps	n.	2	2	2	2	2	2	2	2	2	2	2	2
Humidifier(5)													
Type		Electrode											
Capacity	kg/h	3	3	5	5	5	8	8	8	8	8	8	8
Power input	kW	2.3	2.3	3.8	3.8	3.8	5.9	5.9	5.9	5.9	5.9	5.9	5.9
Outdoor unit(6)													
Model×Qty(6)		CME5×1	CME8×1	CME10×1	CME10×1	CME15×1	CME15×1	CME10×2	CME10×2	CME15×2	CME15×2	CME20×2	CME20×2
Model×Qty(7)		AMAE5×1	AMAE6×1	AMAE8×1	AMAE10×1	AMAE12×1	AMAE12×1	AMAE8×2	AMAE10×2	AMAE12×2	AMAE15×2	AMAE18×2	AMAE20×2
Power supply													
Power source		380V/3Ph/50Hz											
Unit max. operating power input(8)	kW	13.4	14.3	19.0	20.3	21.8	25.0	26.0	34.3	35.7	36.9	39.0	43.6
Unit max. operating current(8)	A	24.4	25.1	33.9	37.9	40.1	46.2	50.2	61.8	66.1	70.4	74.8	83.9
Unit piping connection													
Humidifier water supply	in	1/2"	1/2"	1/2"	1/2"	1/2"	1/2"	1/2"	1/2"	1/2"	1/2"	1/2"	1/2"
Condensing water drainage	in	3/4"	3/4"	3/4"	3/4"	3/4"	3/4"	3/4"	3/4"	3/4"	3/4"	3/4"	3/4"
Refrigerant gas	mm	19	19	19	22	22	22	2×22	2×22	2×22	2×22	2×22	2×28
Refrigerant liquid	mm	16	16	16	16	16	16	2×16	2×16	2×16	2×16	2×19	2×19
Unit external dimensions and Weight													
Width	mm	875	875	1480	1480	1480	1750	1750	2490	2490	2490	3095	3095
Depth	mm	890	890	890	890	890	890	890	890	890	890	890	890
Height	mm	1960	1960	1960	1960	1960	1960	1960	1960	1960	1960	2050	2050
Weight	kg	310	360	370	410	415	620	670	930	980	1020	1210	1250

(1) O:Up flow; U:Down flow

(2) Return air dry bulb temperature 24°C,RH50%,Outdoor dry bulb temperature35°C;

(3) Return air dry bulb temperature 28°C,RH40%,Outdoor dry bulb temperature35°C;

(4) For ESP over 300 Pa, Contact manufacturer;

(5) The default capacity, please refer to "electric heater/ humidifier selection sheet" for other capacity;

(6) Ambient temperature is lower than 40°C. For ambient temperature is higher than 40°C, contact manufacturer;

(7) Meet the requirements of high ambient temperature( lower than 52°C) safe operation, refer to AMAE catalogue for detailed ecification;

(8) Max. operating power input/current: as above spec sheet, outdoor temperature at 45°C, supply fan works at full speed, for A1~A4 unit under the condition of dehumidification plus 100% electric reheat, for A5 unit under the condition cooling plus 100% humidification.

# Technical Parameters

## OPTIMA.DXW

Unit Model		16E1A1	20E1A1	26E1A2	30E1A2	35E1A2	40E2A3	50E2A3	60E2A4	70E2A4	80E2A4	90E2A5	100E2A5
Supply air scheme		O/U											
<b>Cooling capacity</b>													
Total (2)	kW	17.6	21.5	27.9	31.2	36.1	45.8	57.2	62.1	72.2	82.3	90.4	106.7
Sensible(2)	kW	15.8	18.9	24.1	27.0	31.2	40.1	49.8	54.6	63.5	71.6	78.6	91.8
Total (3)	kW	18.1	22.2	28.8	32.2	37.2	47.2	59.0	64.0	74.4	84.9	93.2	110.0
Sensible(3)	kW	16.1	19.3	24.9	27.8	32.2	41.3	51.3	56.4	65.5	73.9	81.1	94.7
<b>Compressor</b>													
Type		Hermetic scroll											
Power input(2)	kW	3.5	4.1	5.2	5.8	7.0	9.0	10.4	11.8	13.9	16.2	18.2	22.6
Current(2)	A	6.9	7.6	10.6	11.7	13.4	19.4	21.2	23.6	27.2	31.2	33.4	42.2
Power input(3)	kW	3.7	4.3	5.4	6.1	7.3	9.4	10.9	12.3	14.5	16.9	19.0	23.6
Current(3)	A	7.1	7.8	10.9	12.0	13.7	19.9	21.7	24.2	27.9	32.0	34.2	43.3
<b>Supply fan</b>													
Type		Caseless backward centrifugal fan											
Qty. of fan	n.	1	1	1	1	1	2	2	3	3	3	3	3
Air volume	m³/h	5750	6320	8900	9600	9600	12600	13600	17800	19200	21000	24600	27900
External static pressure (ESP) (4)	Pa	standard ESP is 75Pa, adjustment range is 50~300Pa											
Power input	kW	1.1	1.3	1.5	1.8	1.8	2.6	2.9	3.6	3.9	4.1	4.4	6.3
Current	A	1.8	2.0	2.3	2.7	2.7	4.1	4.4	5.7	6.2	6.5	6.8	8.6
Power input(5)	kW	1.6	1.6	2.3	2.3	2.3	3.2	3.2	4.8	4.8	4.8	6.9	6.9
Current(5)	A	2.5	2.5	3.9	3.9	3.9	5.1	5.1	7.1	7.1	7.1	11.7	11.7
<b>Air filter</b>													
G4 plate													
<b>Water condenser</b>													
Water flow	m³/h	3.9	4.8	6.2	7.0	7.3	11.0	12.4	14.1	16.0	18.1	20.3	23.7
Pressure drop	kPa	27.0	26.6	28.6	30.7	26.0	46.4	44.3	44.8	46.3	48.4	34.3	36.7
Pressure drop(with valve)	kPa	33.5	36.1	44.6	50.7	47.5	63.4	62.8	58.3	61.3	69.9	51.8	55.2
Water volume	L	1.1	1.4	1.8	1.9	2.2	4.0	4.5	5.2	5.8	6.4	7.3	8.1
<b>Electric heater(6)</b>													
Type		Stainless steel electric heater											
Heating capacity	kW	6	6	9	9	9	13.5	13.5	18	18	18	18	18
Working steps	n.	2	2	2	2	2	2	2	2	2	2	2	2
<b>Humidifier(6)</b>													
Type		Electrode											
Capacity	kg/h	3	3	5	5	5	8	8	8	8	8	8	8
Power input	kW	2.3	2.3	3.8	3.8	3.8	5.9	5.9	5.9	5.9	5.9	5.9	5.9
<b>Power supply</b>													
Power source		380V/3Ph/50Hz											
Unit max. operating power input(7)	kW	11.6	12.5	17.1	18.2	19.7	21.8	23.0	29.1	30.8	32.4	34.3	41.0
Unit max. operating current(7)	A	19.1	20.1	28.4	30.1	32.1	36.4	37.8	47.5	50.2	53.0	58.9	69.5
<b>Unit piping connection</b>													
Humidifier water supply	in	1/2"	1/2"	1/2"	1/2"	1/2"	1/2"	1/2"	1/2"	1/2"	1/2"	1/2"	1/2"
Condensing water drainage	in	3/4"	3/4"	3/4"	3/4"	3/4"	3/4"	3/4"	3/4"	3/4"	3/4"	3/4"	3/4"
Inlet/outlet chilling water	in	1-1/4"	1-1/4"	1-1/4"	1-1/4"	1-1/4"	1-1/2"	1-1/2"	1-1/22"	2"	2"	2"	2"
<b>Unit external dimensions and Weight</b>													
Width	mm	875	875	1480	1480	1480	1750	1750	2490	2490	2490	3095	3095
Depth	mm	890	890	890	890	890	890	890	890	890	890	890	890
Height	mm	1960	1960	1960	1960	1960	1960	1960	1960	1960	1960	2050	2050
Weight	kg	322	374	385	423	431	656	709	971	1013	1076	1256	1300

(1) O:Up flow; U:Down flow

(2) Return air dry bulb temperature 24℃,RH50%,inlet chilling water temperature 30℃, standard chilling water flow;

(3) Return air dry bulb temperature 28℃,RH40%,inlet chilling water temperature 30℃,standard chilling water flow;

(4) For ESP over 300 Pa, Contact manufacturer;

(5) Option, AC fan;

(6) The default capacity, please refer to "electric heater/ humidifier selection sheet" for other capacity;

(7) Max. operating power input: as above spec sheet, inlet chilling water temperature 40℃,for A1~A4 unit under the condition of dehumidification plus 100% electric reheat, for A5 unit under the condition cooling plus 100% humidification.

# Technical Parameters

## OPTIMA.CW

Unit Model		20A1	30A1	40A2	45A2	55A3	65A3	80A4	100A4	120A5	140A5
<b>Supply air scheme</b>		O/U									
<b>Cooling capacity</b>											
Total (2)	kW	24.8	30.3	40.8	47.7	55.8	66.5	80.5	100.2	112.1	134.5
Sensible(2)	kW	22.1	26.2	36.8	41.5	48.8	57.7	72.7	86.7	104.2	121.0
Total (3)	kW	19.3	23.8	31.5	37.4	43.5	50.0	62.7	76.1	92.8	112.9
Sensible(3)	kW	18.3	21.3	29.5	34.0	41.2	47.0	59.0	69.4	90.0	106.2
<b>Cooling coil</b>											
Water flow(2)	m <sup>3</sup> /h	4.2	5.2	6.8	8.1	9.1	11.0	13.6	16.8	18.3	21.8
Water flow(3)	m <sup>3</sup> /h	3.3	4.1	5.4	6.4	7.4	8.6	10.7	13.0	16.0	19.6
Water pressure drop(coil+valve)(2)	kPa	80.6	78.1	89.0	83.2	80.8	81.7	96.5	101.2	147.0	157.2
Water pressure drop(coil+valve)(3)	kPa	52.3	51.8	59.7	52.8	58.7	57.6	65.1	76.4	109.7	110.9
<b>Supply fan</b>											
Type	Caseless backward centrifugal fan										
Qty. of fan		1	1	1	1	2	2	3	3	3	3
Air volume	m <sup>3</sup> /h	6750	6750	9600	9600	15300	15300	21600	21600	28900	28900
External static pressure (ESP) (4)	Pa	Standard ESP is 75Pa, adjustment range is 50-300Pa									
Power input	kW	1.4	1.5	2.2	2.5	2×1.7	2×2.0	3×1.7	3×2.0	3×2.1	3×2.5
Current	A	2.3	2.5	3.2	3.7	2×2.8	2×3.1	3×2.8	3×3.1	3×3.3	3×3.7
Power input(5)	kW	1.6	1.6	2.7	2.7	2×1.6	2×2.7	3×1.6	3×2.7	3×2.7	3×2.7
Current(5)	A	2.8	2.8	4.1	4.1	2×2.8	2×4.1	3×2.8	3×4.1	3×4.1	3×4.1
<b>Air filter</b>											
G4 plate											
<b>Electric heater(6)</b>											
Type	Stainless steel electric heater										
Heating capacity	kW	6	6	9.0	9.0	13.5	13.5	18	18	18	18
Working steps	n.	2	2	2	2	2	2	2	2	2	2
<b>Humidifier(6)</b>											
Type	Electrode										
Capacity	kg/h	3	3	5	5	8	8	8	8	8	8
Power input	kW	2.3	2.3	3.8	3.8	6.0	6.0	6.0	6.0	6.0	6.0
<b>Power supply</b>											
Power source	380V/3Ph/50Hz										
Unit max. operating power input(7)	kW	11.2	11.3	15.0	15.3	22.9	23.5	29.1	30.0	30.3	31.5
Unit max. operating current input(7)	A	17.1	17.3	22.4	22.9	35.2	35.8	44.9	45.8	46.4	47.6
<b>Unit piping connection</b>											
Humidifier water supply	in	1/2"	1/2"	1/2"	1/2"	1/2"	1/2"	1/2"	1/2"	1/2"	1/2"
Condensing water drainage	in	3/4"	3/4"	3/4"	3/4"	3/4"	3/4"	3/4"	3/4"	3/4"	3/4"
Inlet/outlet chilled water	in	1 1/4"	1 1/4"	1 1/4"	1 1/4"	1 1/2"	1 1/2"	2"	2"	2 1/2"	2 1/2"
<b>Unit external dimensions and Weight</b>											
Width	mm	875	875	1480	1480	1480	1750	1750	2490	2490	2490
Depth	mm	890	890	890	890	890	890	890	890	890	890
Height	mm	1960	1960	1960	1960	1960	1960	1960	1960	1960	1960
Weight	kg	322	374	385	423	431	656	709	971	1013	1076

(1) O:Up flow; U:Down flow;

(2) Return air dry bulb temperature 24°C,RH50%.inlet/outlet chilled water temperature 7°C/12°C;

(3) Return air dry bulb temperature 28°C,RH40%.inlet/outlet chilled water temperature 10°C/15°C;

(4) For ESP over 300 Pa, Contact manufacturer;

(5) Option, AC fan;

(6) The default capacity, please refer to "electric heater/ humidifier selection sheet" for other capacity;

(7) Max. operating power input and current input: as above spec sheet, under the condition of dehumidification plus 100% electric reheat.

# Technical Parameters

## OPTIMA.CWD

Unit Model		20A1	30A1	40A2	45A2	55A3	65A3	80A4	100A4	120A5	140A5
Supply air scheme(1)		U/O									
Cooling capacity(2)											
Total (3)	kW	24.8	30.3	40.8	47.7	55.8	66.5	80.5	100.2	112.1	134.5
Sensible(3)	kW	22.1	26.2	36.8	41.5	48.8	57.7	72.7	86.7	104.2	121.0
Total (4)	kW	19.3	23.8	31.5	37.4	43.5	50.0	62.7	76.1	92.8	112.9
Sensible(4)	kW	18.3	21.3	29.5	34.0	41.2	47.0	59.0	69.4	90.0	106.2
cooling coil											
Water flow(3)	m <sup>3</sup> /h	4.2	5.2	6.8	8.1	9.1	11.0	13.6	16.8	18.3	21.8
Water flow(4)	m <sup>3</sup> /h	3.3	4.1	5.4	6.4	7.4	8.6	10.7	13.0	16.0	19.6
Water pressure drop(coil+valve)(3)	kPa	80.6	78.1	89.0	83.2	80.8	81.7	96.5	101.2	147.0	157.2
Water pressure drop(coil+valve)(4)	kPa	52.3	51.8	59.7	52.8	58.7	57.6	65.1	76.4	109.7	110.9
Supply fan											
Type	Caseless backward centrifugal fan										
Qty. of fan	n.	1	1	1	1	2	2	3	3	3	3
Air volume	m <sup>3</sup> /h	6750	6750	9600	9600	15300	15300	21600	21600	28900	28900
External static pressure (ESP) (5)	Pa	125Pa									
Power input	kW	1.7	2.0	2.4	2.6	2×2.1	2×2.5	3×2.1	3×2.4	3×2.5	3×2.7
Current	A	2.8	3.1	3.3	3.6	2×3.3	2×3.7	3×2.8	3×3.5	3×3.7	3×4.1
Power input(6)	kW	1.6	1.6	2.7	2.7	2×1.6	2×2.7	3×1.6	3×2.7	3×2.7	3×2.7
Current(6)	A	2.8	2.8	4.1	4.1	2×2.8	2×4.1	3×2.8	3×4.1	3×4.1	3×4.1
Air filter		G4 plate									
Electric heater(7)											
Type	Stainless steel electric heater										
Heating capacity	kW	6	6	9.0	9.0	13.5	13.5	18	18	18	18
Working steps	n.	2	2	2	2	2	2	2	2	2	2
Humidifier(7)											
Type	Electrode										
Capacity	kg/h	3	3	5	5	8	8	8	8	8	8
Power input	kW	2.3	2.3	3.8	3.8	6.0	6.0	6.0	6.0	6.0	6.0
Power supply											
Power source	380V/3Ph/50Hz										
Unit max. operating power input(8)	kW	11.5	11.8	15.2	15.4	23.7	24.5	30.3	31.2	31.5	32.1
Unit max. operating current input(8)	A	17.6	17.9	22.5	22.8	36.2	37.0	44.9	47.0	47.6	48.8
Unit piping connection											
Humidifier water supply	in	1/2"	1/2"	1/2"	1/2"	1/2"	1/2"	1/2"	1/2"	1/2"	1/2"
Condensing water drainage	in	3/4"	3/4"	3/4"	3/4"	3/4"	3/4"	3/4"	3/4"	3/4"	3/4"
Inlet/outlet chilled water	in	1 1/4"	1 1/4"	1 1/4"	1 1/4"	1 1/2"	1 1/2"	2"	2"	2 1/2"	2 1/2"
Unit external dimensions and Weight											
Width	mm	875	875	1480	1480	1750	1750	2490	2490	3095	3095
Depth	mm	890	890	890	890	890	890	890	890	890	890
Height	mm	1960	1960	1960	1960	1960	1960	1960	1960	2050	2050
Weight	kg	327	356	408	448	504	556	600	642	730	785

(1) O:Up flow; U:Down flow;

(2) Single cooling coil offers. Under the standard condition, the total cooling capacity will increase by 45% when two coils work at the same time

(3) Return air dry bulb temperature 24°C,RH50%.inlet/outlet chilled water temperature 7°C/12°C;

(4) Return air dry bulb temperature 28°C,RH40%.inlet/outlet chilled water temperature 10°C/15°C;

(5) For ESP over 300 Pa, Contact manufacturer;

(6) Option, AC fan;

(7) The default capacity, please refer to "electric heater/ humidifier selection sheet" for other capacity;

(8) Max. operating power input and current input: as above spec sheet, under the condition of dehumidification plus 100% electric reheat.

## Technical parameters

### CME

Unit model		CME5	CME8	CME10	CME15	CME20	CME25
Capacity (1)	kW	20.5	29.6	35.4	47.6	67.4	73.1
<b>Fan</b>							
Fan qty.	No.	1	1	1	2	2	2
Air flow rate	m <sup>3</sup> /h	5600	10100	9700	11600	20100	19100
Input power	kW	0.37	0.63	0.63	0.74	1.26	1.26
Input current	A	1.7	3	3	3.4	6	6.0
<b>Connection tube size</b>							
Gas pipe	mm	19	22	22	22	28	35
Liquid pipe	mm	12	16	16	19	19	22
<b>Unit external dimensions and Weight</b>							
Length	mm	1140	1340	1340	1540	2400	2400
Width	mm	475	620	620	620	630	630
Height	mm	770	1070	1070	1070	1135	1135
Weight	kg	47	95	110	130	155	185

(1)The capacity is rated at entering air temperature 35°C and condensing temperature 50°C condition.

### AMAE

Unit model		AMAE5	AMAE6	AMAE8	AMAE10	AMAE12	AMAE15	AMAE18	AMAE20
Capacity (1)	kW	24.2	29.7	36.2	41.3	50.7	57.2	62.4	74.3
<b>Fan</b>									
Fan qty.	No.	1	1	1	1	2	2	2	2
Air flow rate	m <sup>3</sup> /h	12500	11600	11800	11500	23500	22000	23400	22600
Input power	kW	0.63	0.63	0.63	0.63	1.26	1.26	1.26	1.26
Input current	A	2.8	2.8	2.8	2.8	5.6	5.6	5.6	5.6
<b>Connection tube size</b>									
Gas pipe	mm	19	19	19	22	22	22	22	28
Liquid pipe	mm	16	16	16	16	16	16	19	19
<b>Unit external dimensions and Weight</b>									
Length	mm	1365	1365	1665	1665	1985	1985	2785	2785
Width	mm	620	620	620	620	620	620	620	620
Height	mm	1080	1080	1080	1080	1080	1080	1080	1080
Weight	kg	103	116	135	152	173	182	206	220

(1)The capacity is rated at entering air temperature 35°C and condensing temperature 50°C condition.

# Unit Dimension Drawing

## A1 Unit Cabinet Dimension Drawing For Up Flow Unit

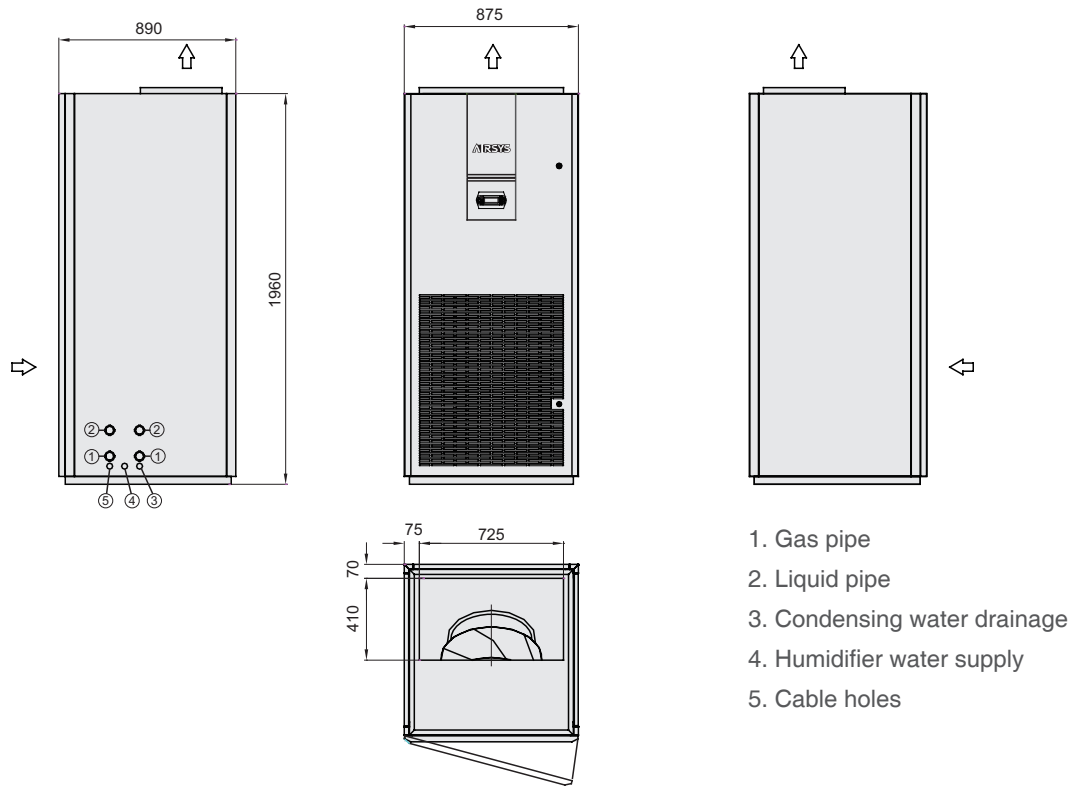

## A1 Unit Cabinet Dimension Drawing For Under Flow Unit

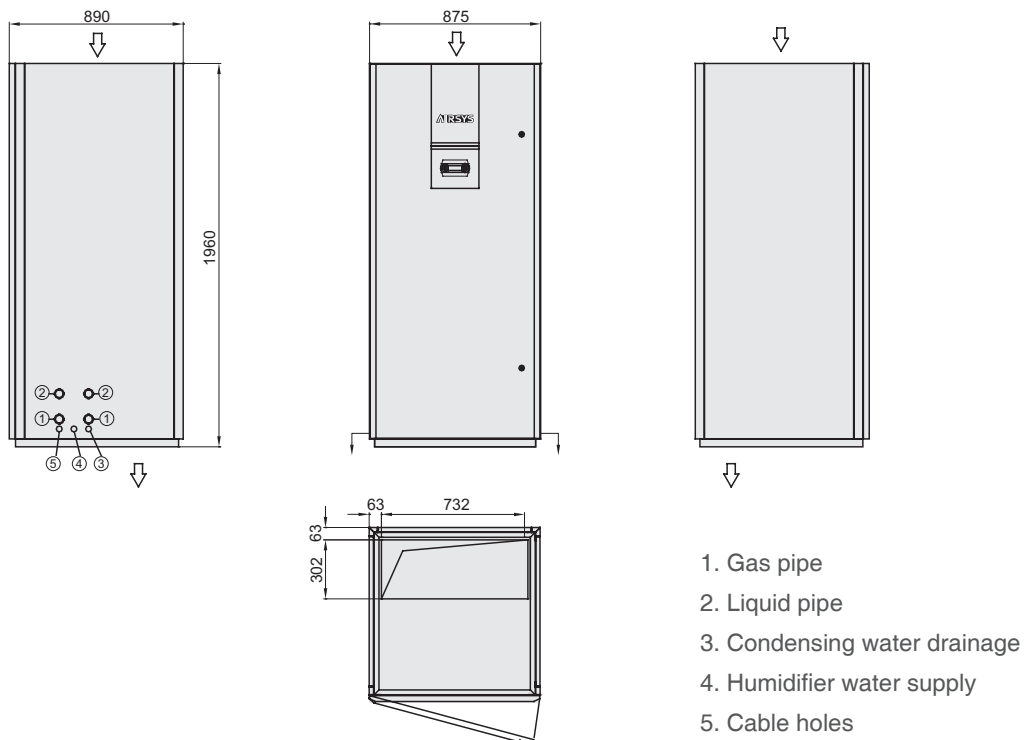



### A2 Unit Cabinet Dimension Drawing For Up Flow Unit

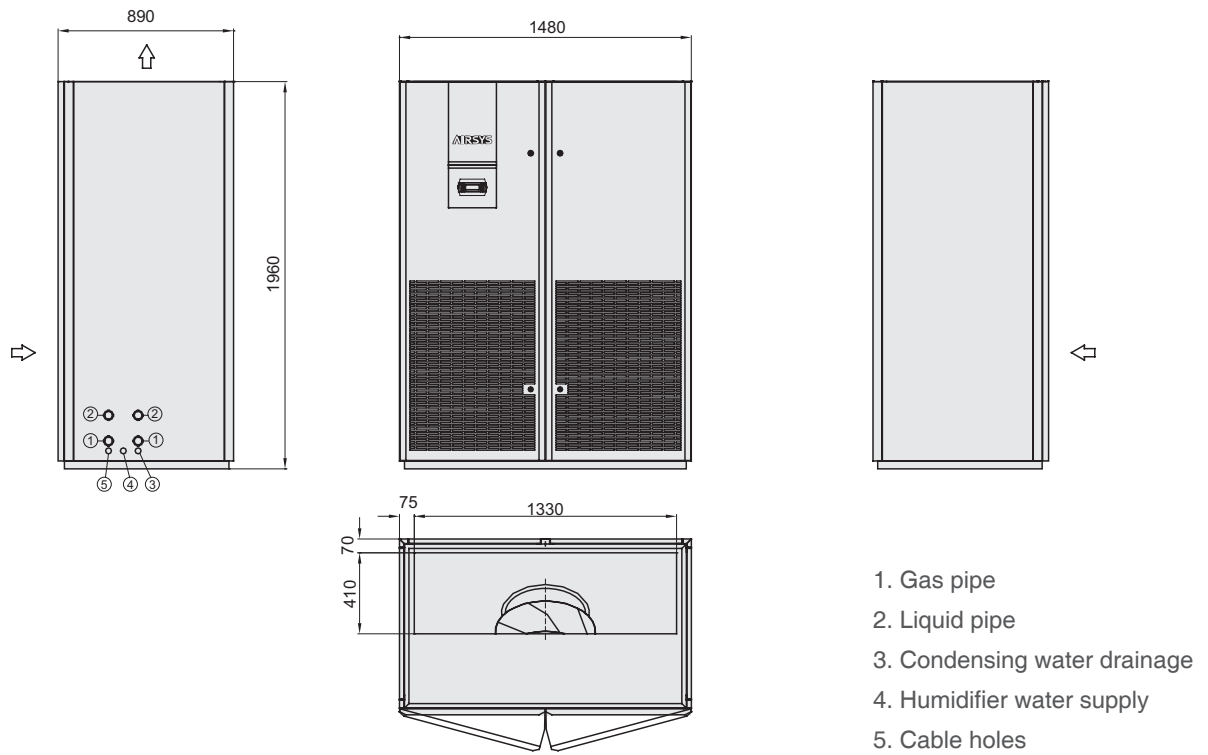

### A2 Unit Cabinet Dimension Drawing For Under Flow Unit

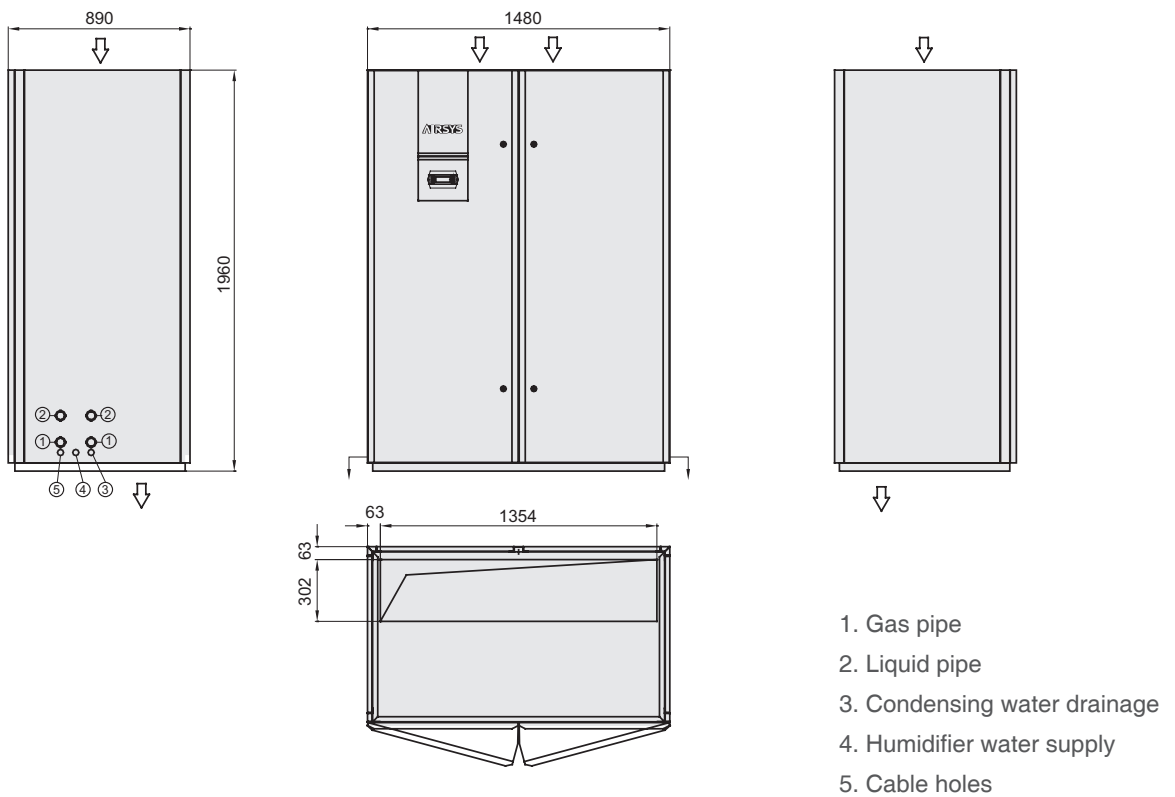

### A3 Unit Cabinet Dimension Drawing For Up Flow Unit

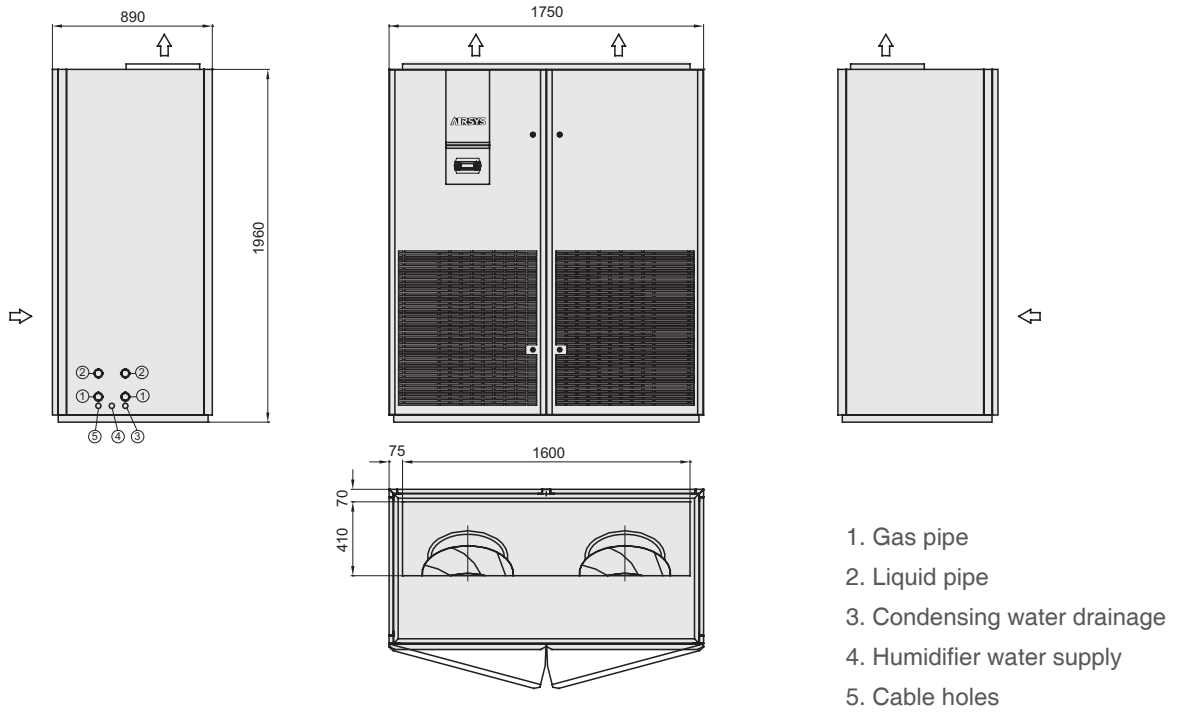

### A3 Unit Cabinet Dimension Drawing For Under Flow Unit

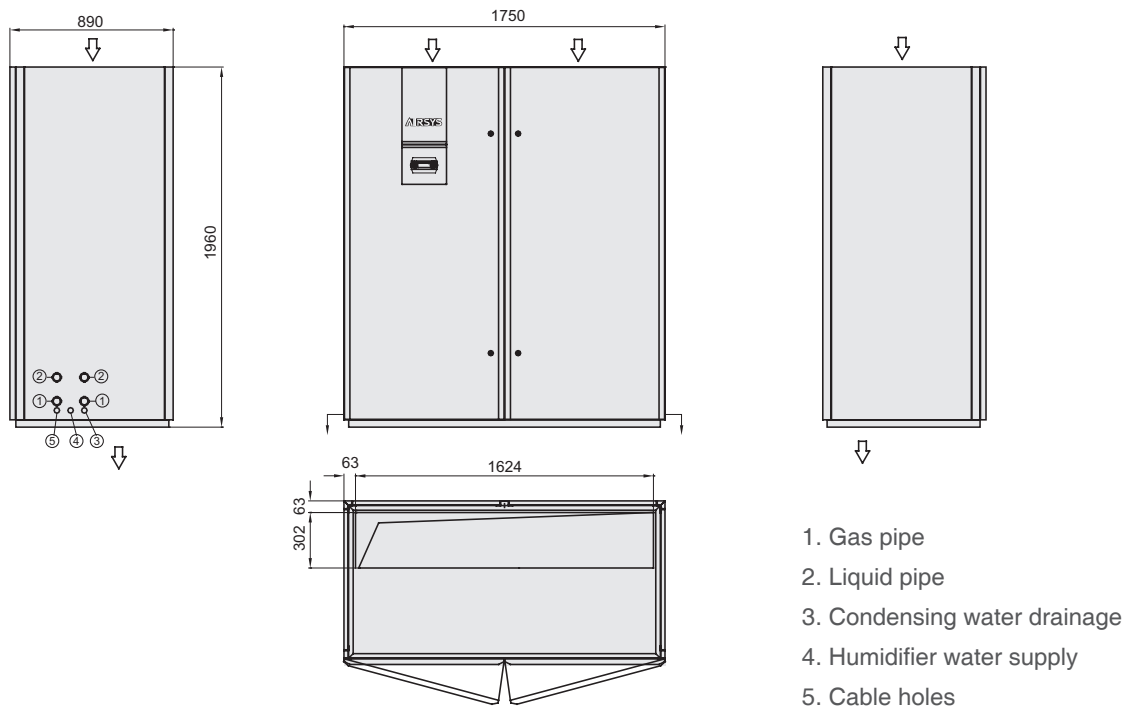

### A4 Unit Cabinet Dimension Drawing For Up Flow Unit

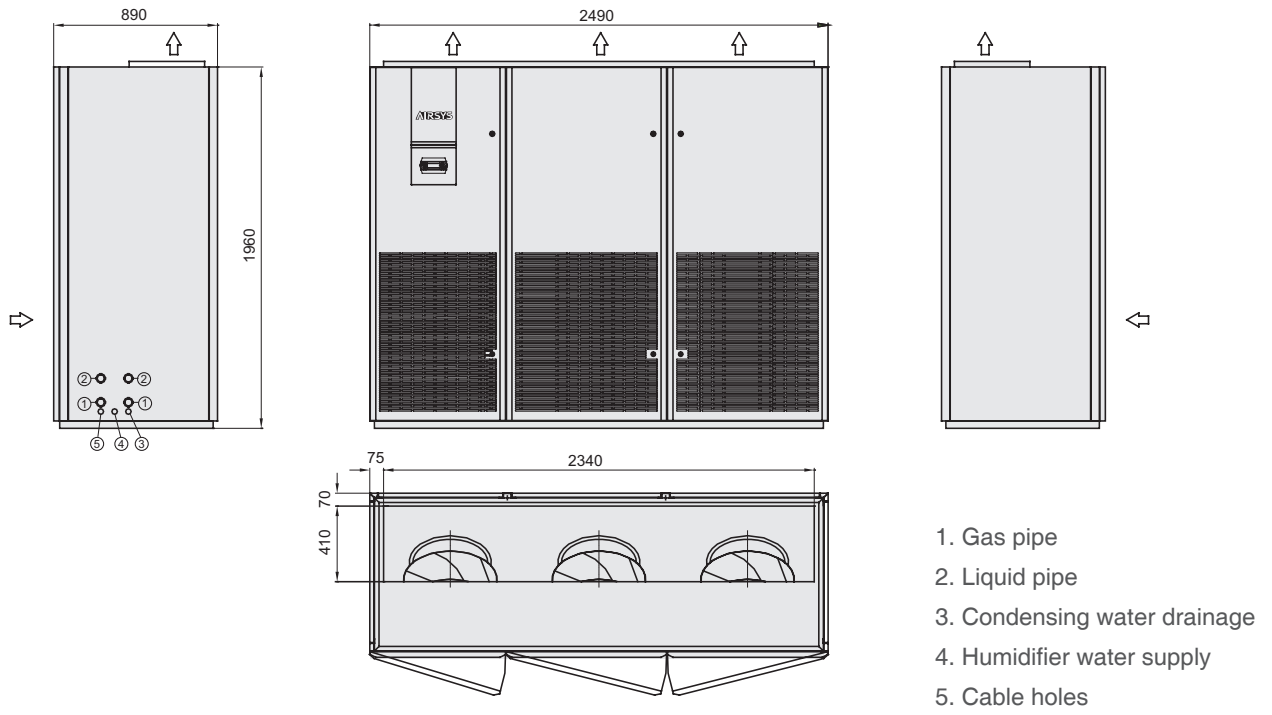

### A4 Unit Cabinet Dimension Drawing For Under Flow Unit

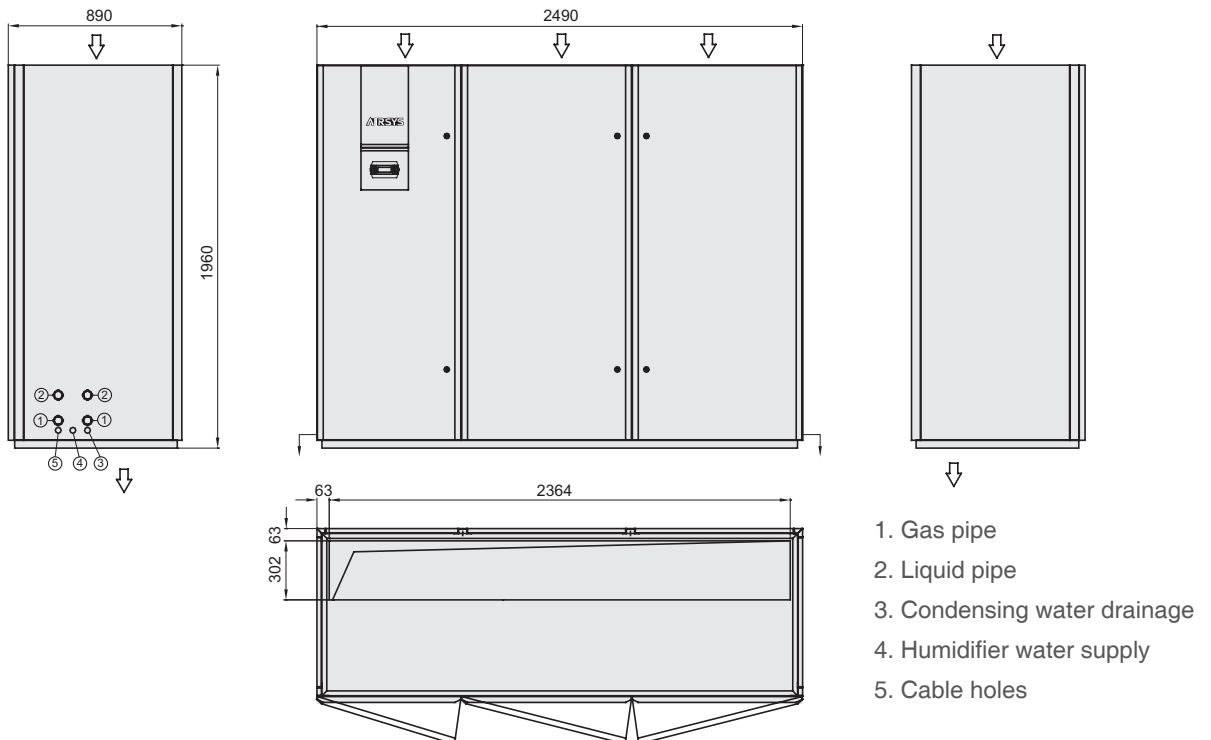

### A5 Unit Cabinet Dimension Drawing For Up Flow Unit

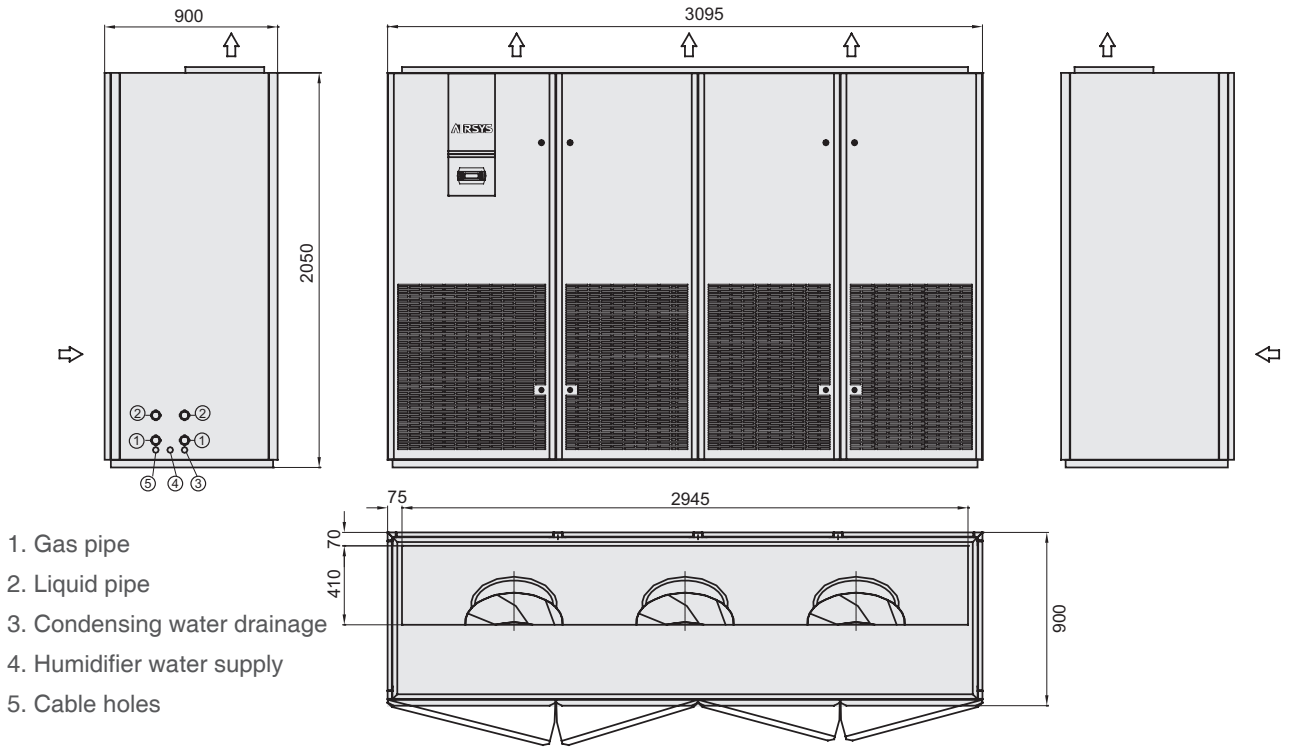

### A5 Unit Cabinet Dimension Drawing For Under Flow Unit

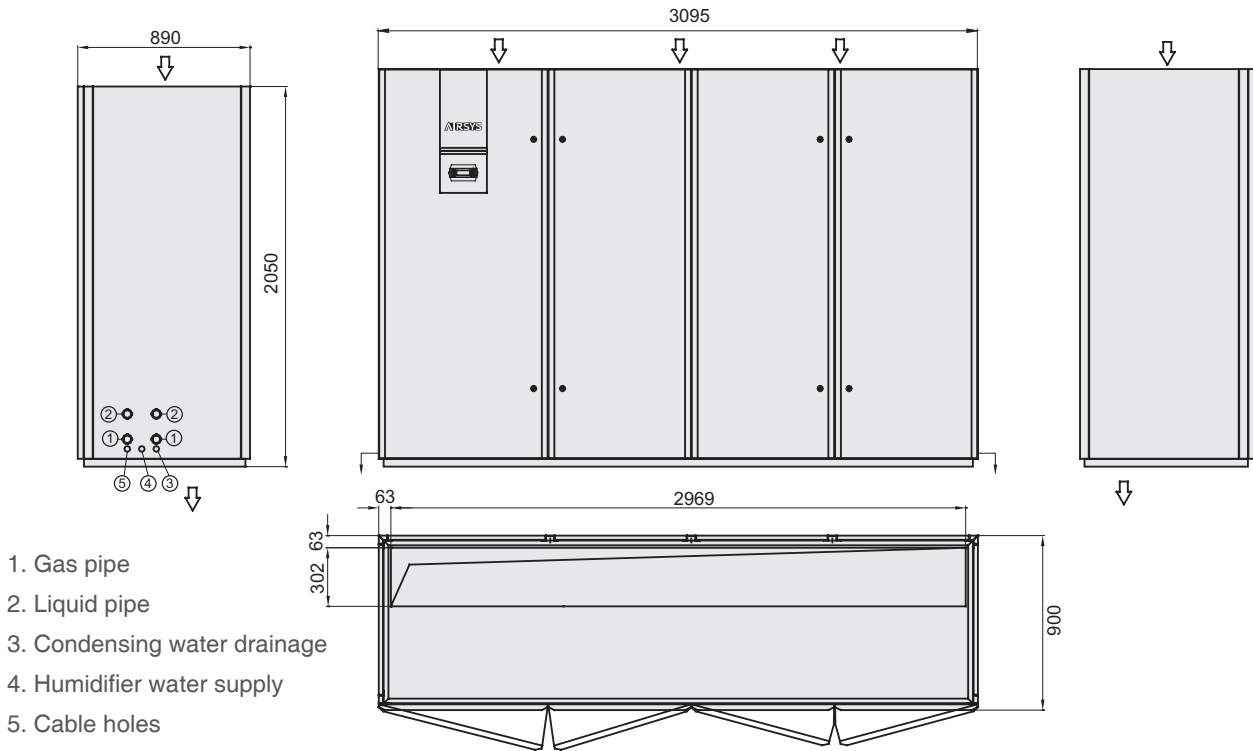

# CME Dimension Drawing

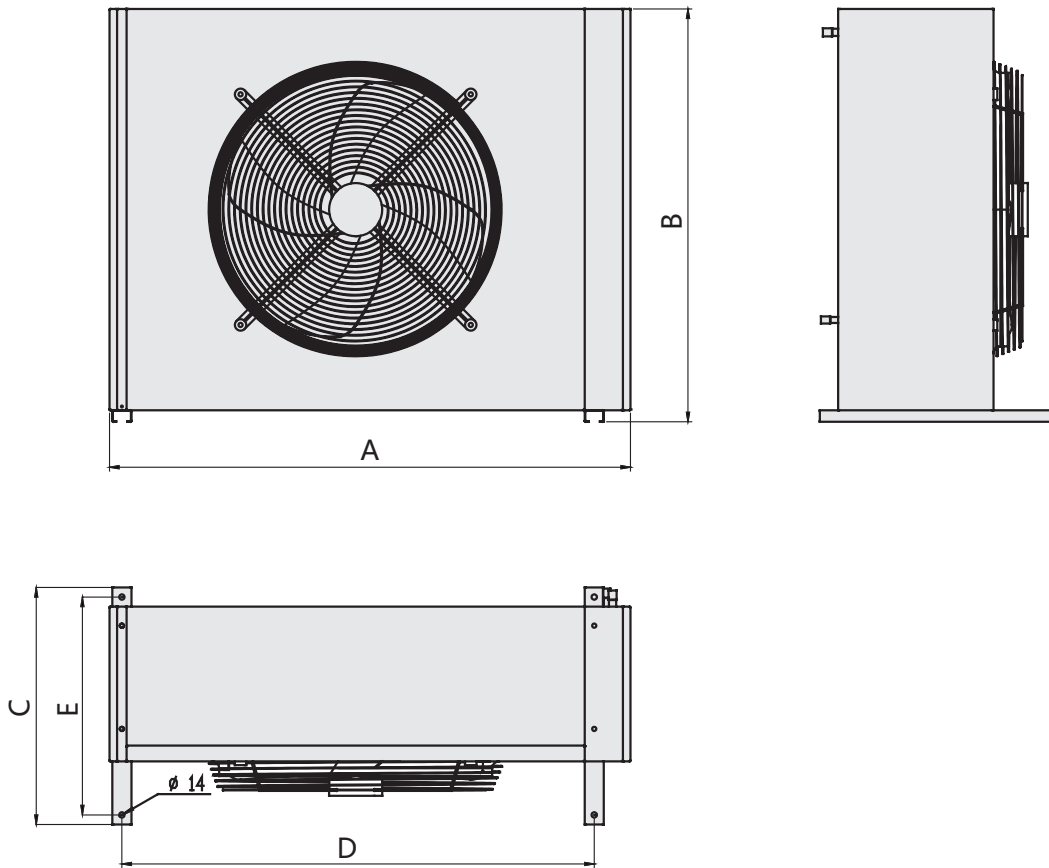

	CME5	CME8	CME10	AMAE5	AMAE6	AMAE8	AMAE10
A	1140	1340	1340	1365	1365	1665	1665
B	770	1070	1070	1080	1080	1080	1080
C	475	620	620	620	620	620	620
D	1037	1237	1237	1237	1237	1537	1537
E	425	570	570	570	570	570	570

Remark: Vertical installation type is default, please indicate in the contract if horizontal installation type is required.

# AMAE Dimension Drawing

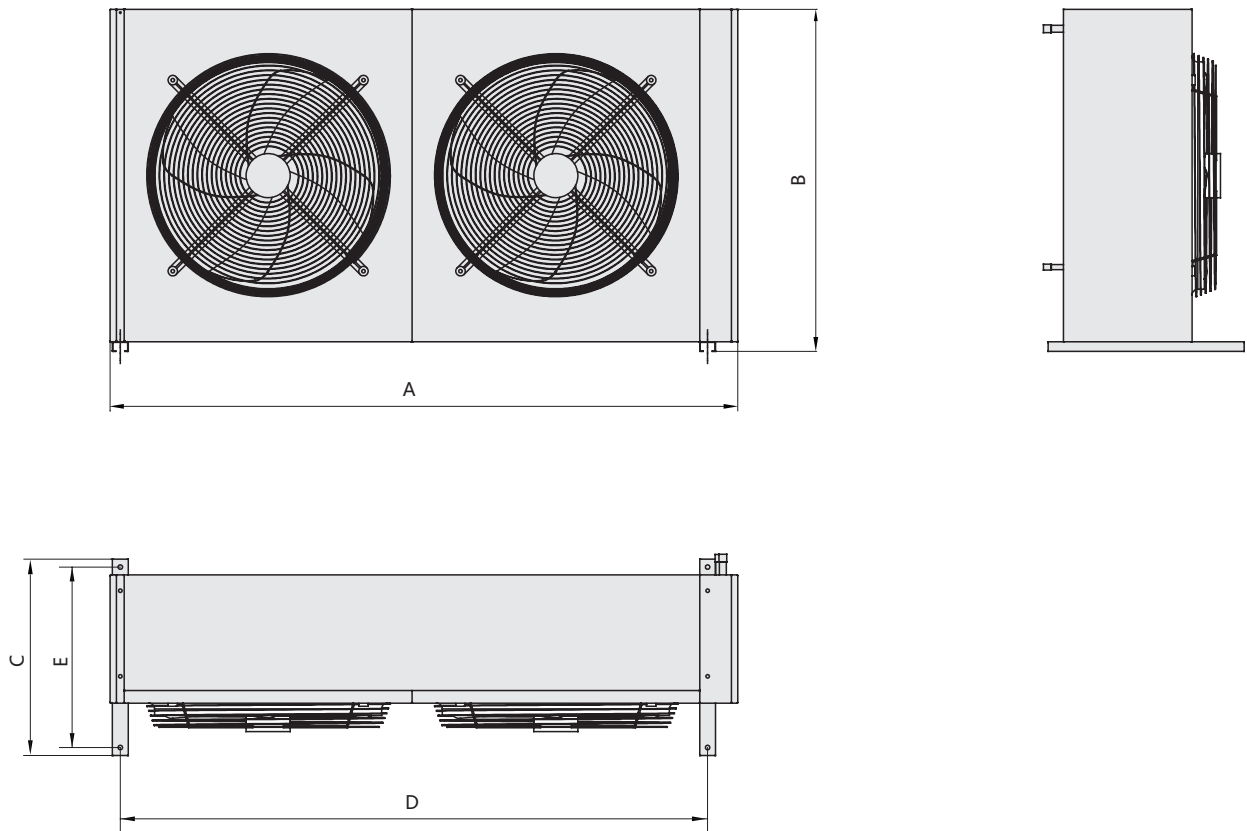

	CME15	CME20	CME25	AMAE12	AMAE15	AMAE18	AMAE20
A	1540	2400	2400	1985	1985	2785	2785
B	1070	1135	1135	1080	1080	1080	1080
C	620	630	630	620	620	620	620
D	1437	2160	2160	1857	1857	2657	2657
E	570	580	580	570	570	570	570

Remark: Vertical installation type is default, please indicate in the contract if horizontal installation type is required.

AIRSYS is a cooling product and solution provider for ICT (Information & Communication Technology) industry.

The products include:

- Air conditioner and Chiller for IT room and large data center
- Intelligent Control system (BAS) for IT room and data center
- Air conditioning equipments for telecom shelters
- Intelligent control system for shelter cooling.

Air conditioner and heat exchanger for telecom cabinets.

The solution include:

- Cooling system design
- System integration
- Installation and Commissioning
- Operation and Maintenance

AIRSYS is also a global leader in providing cooling solution for Medical Imaging System.

AIRSYS Refrigeration Engineering Technology (Beijing) Co. Ltd.

Add: No.28, LuGuDong Str., Shijingshan District, Beijing, China Post code: 100040

Tel:+86-10-6865 6161 Fax:+86-10-6865 2453

Callcenter :+86-400-820-5515

[www.air-sys.com](http://www.air-sys.com)